

A Look at TRT L1 Alignment

John Alison
Andrea Bocci

Outline:

Barrel
Endcap A and C
Conclusions

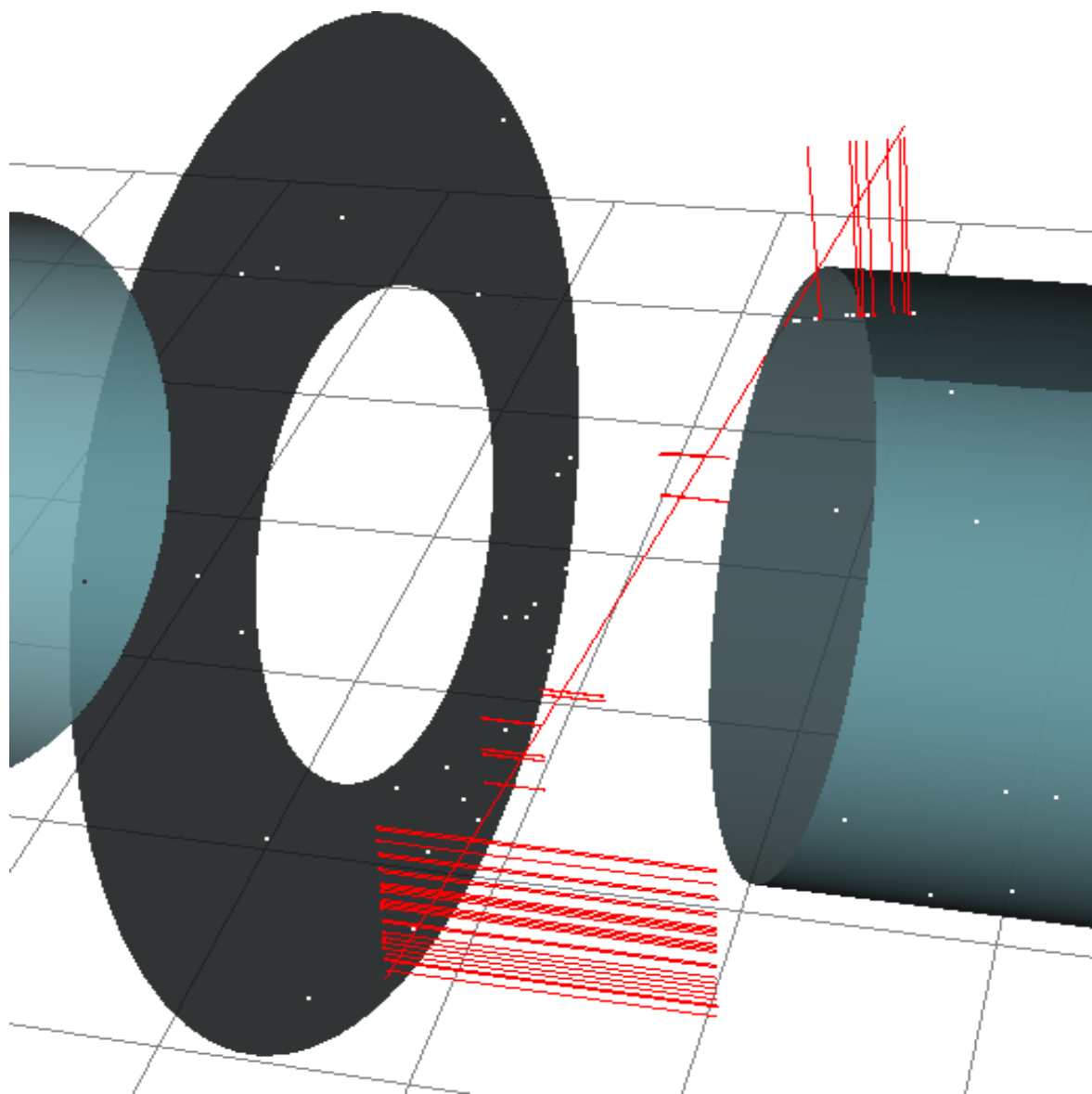



Disclaimer

All results presented here are preliminary.

- TRT Calibration for Xe with B-field still has not been done.
(I'm using M.C. relation derived from CTB)
- Detector stability was not a priority during this period of data taking
- There are remaining issues to be understood.



TRT Alignment

Ran the TRT alignment with run 90275

- chosen for statistics / B-field / off-the-record approval of hw experts
- ran with filtered ESDs from Thijs
- 76,000 total events

Aligned the TRT Barrel (5DoF) and 2 Endcaps (6DoF)

Track Selection

- tracks used in the alignment
 - $p_T > 2 \text{ GeV}$ / $n_{\text{Si}} > 5$ / $n_{\text{TRT}} > 20$
- tracks used in monitoring plots
 - $p_T > 5 \text{ GeV}$ / $n_{\text{Si}} \& n_{\text{TRT}} > 1$

Starting alignment: HLT-UPD1-00

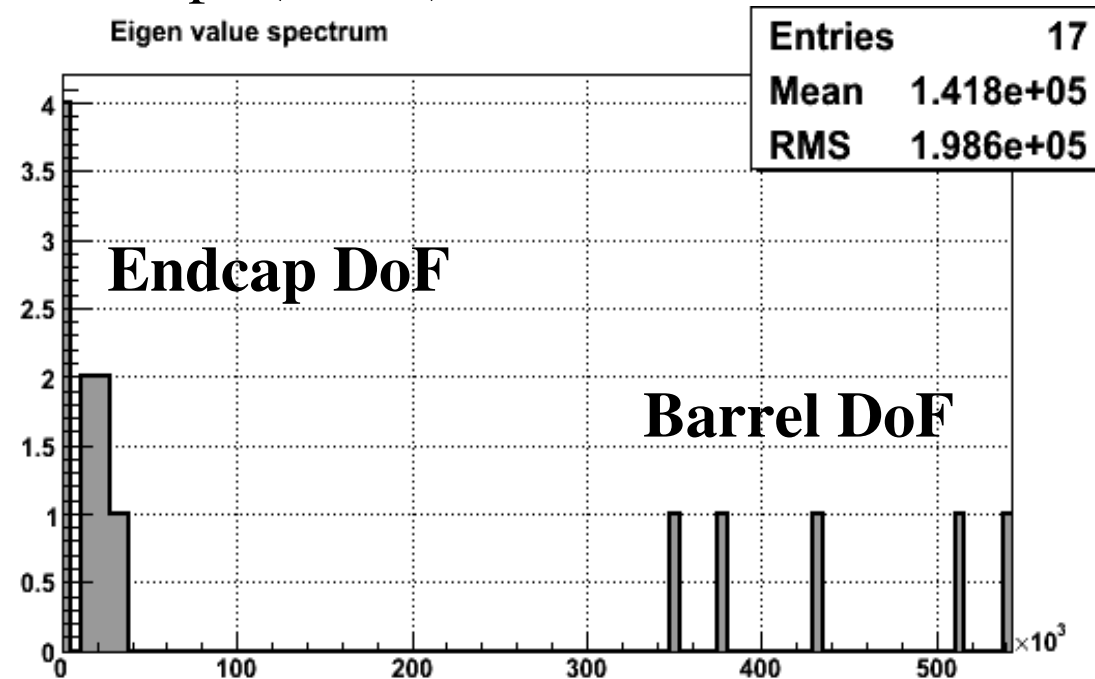



TRT Alignment

- Ran 20 iterations
- Hits and Tracks used in the alignment increase with iteration, whereas the Chi2 decreases
- In plots which follow:
 - red is before TRT L1 alignment
 - black is after TRT L1 alignment

Change in Chi2 vs Iteration

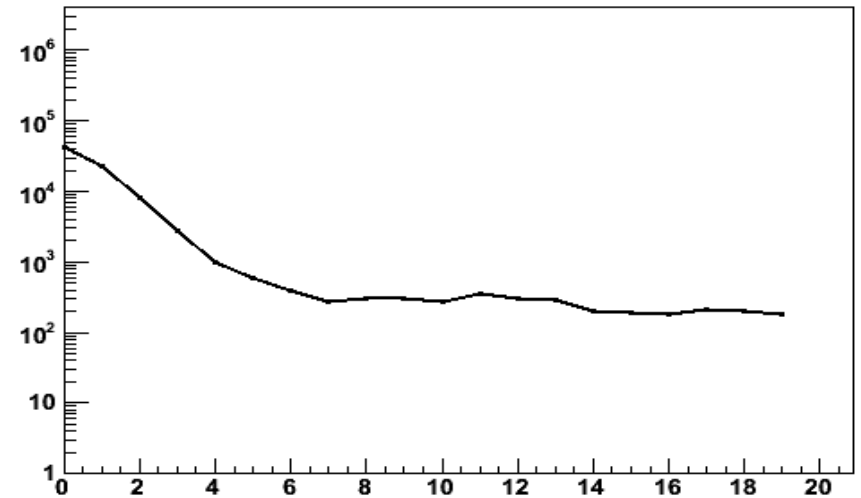

Tracks vs Iteration

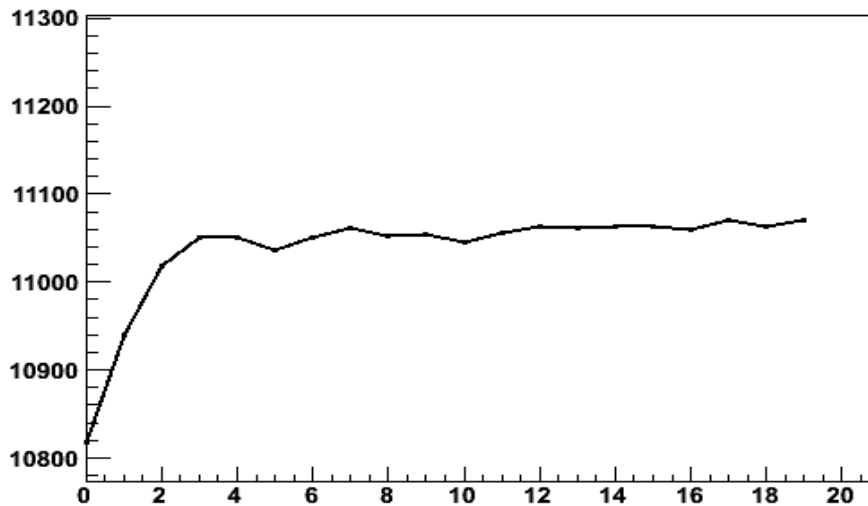

Hits vs Iteration

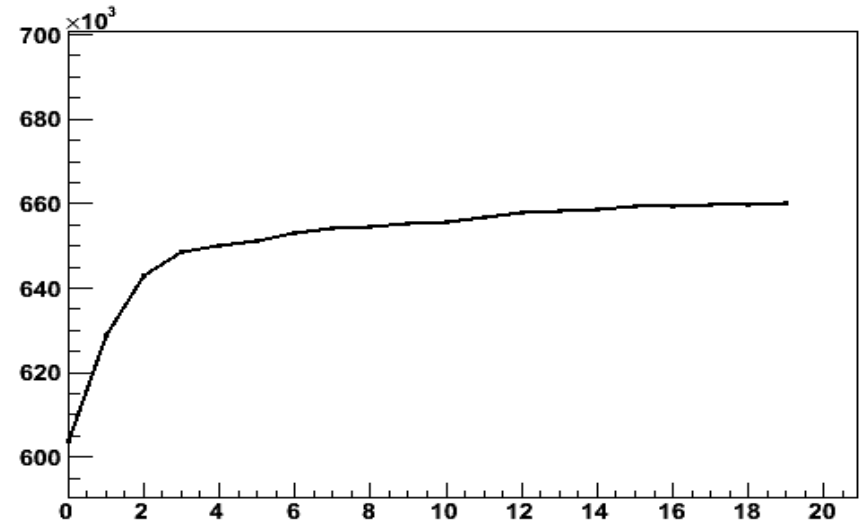



TRT Barrel

Barrel convergence complete, hits increase w/ iteration

Misalignments: translations <100 microns (same direction as in M6)

rotations < milli-radian (rotz same direction and in M6)

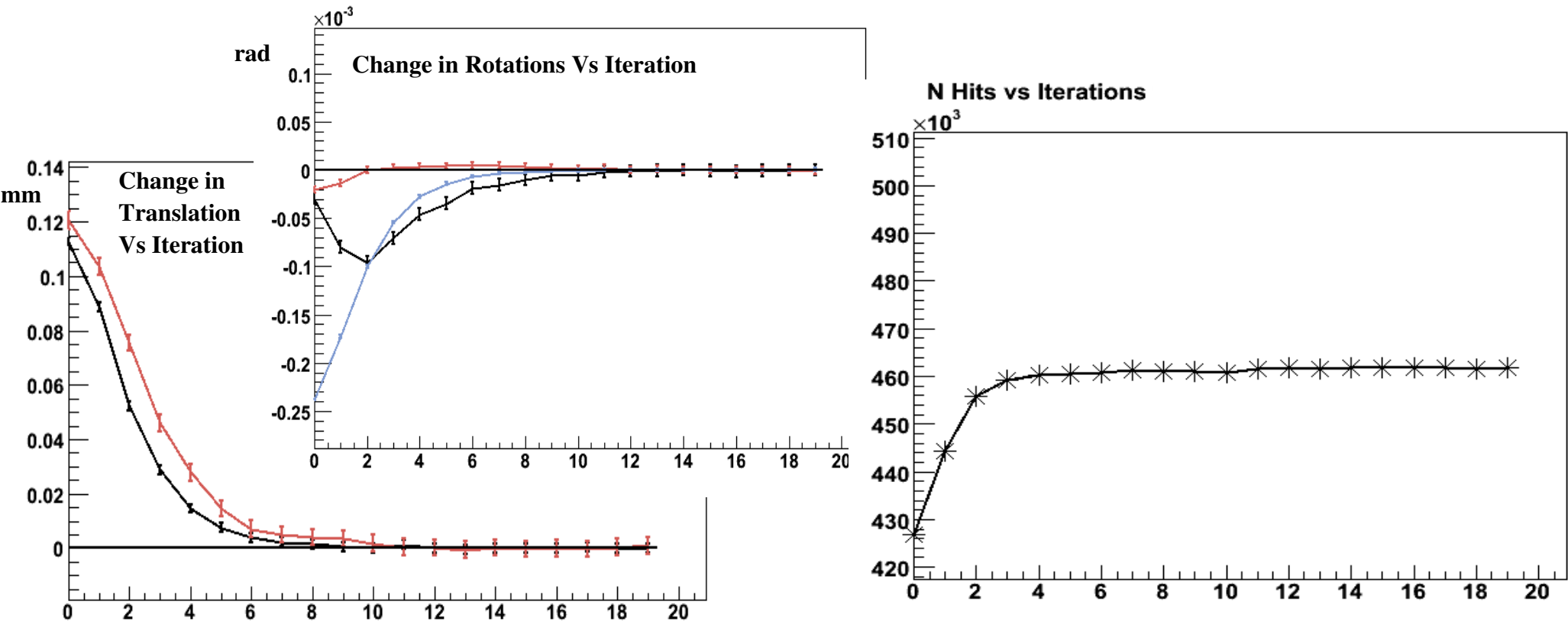



TRT Barrel

UnBiased Residual for the TRT Barrel

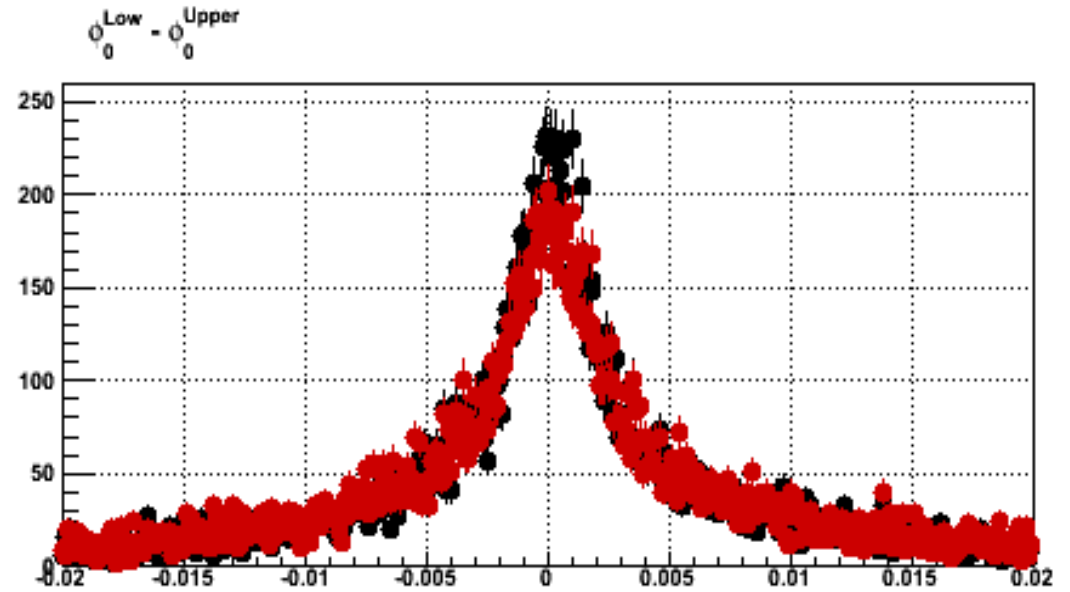
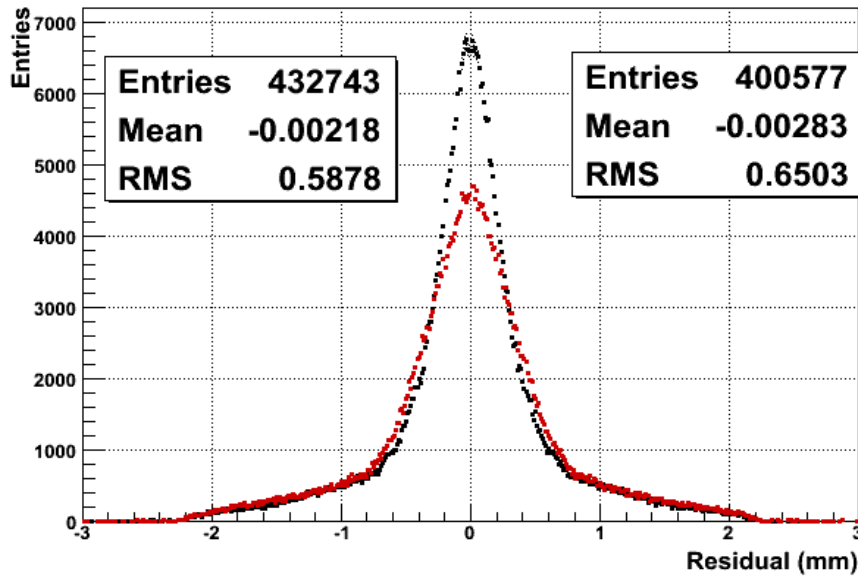

Ratio Hits to total measurements vrs Straw Layer (Intergrated over Phi) for TRT Barrel layer

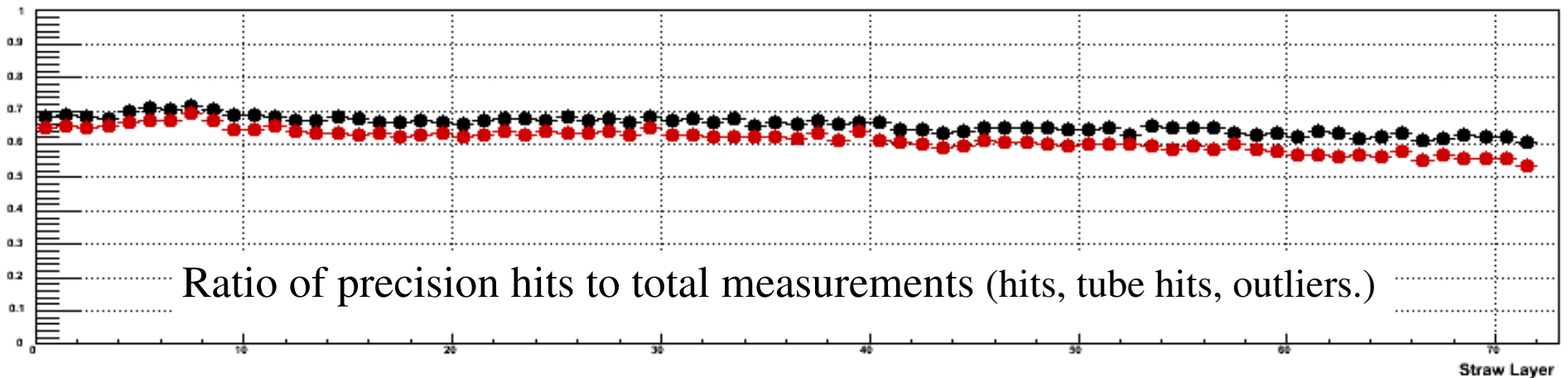



TRT Barrel

Hits vrs phi sector for Barrel layer0

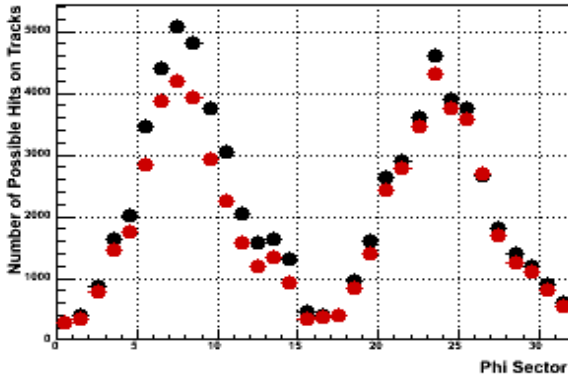

Hits vrs phi sector for Barrel layer1

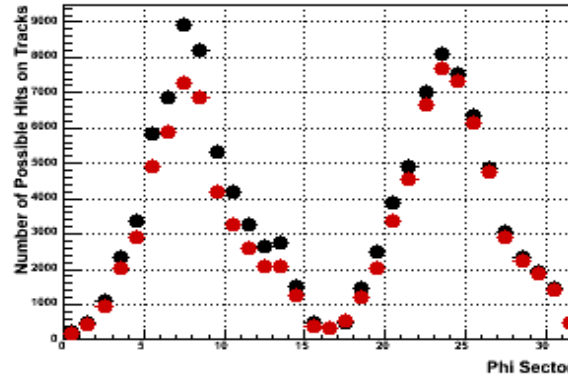

Hits vrs phi sector for Barrel layer2

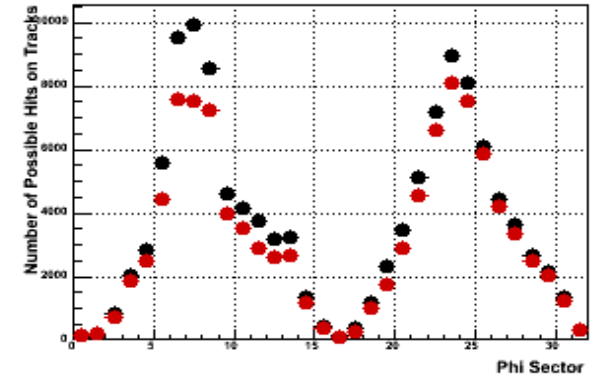

Residual RMS vs Phi Sector for TRT Barrel Layer1

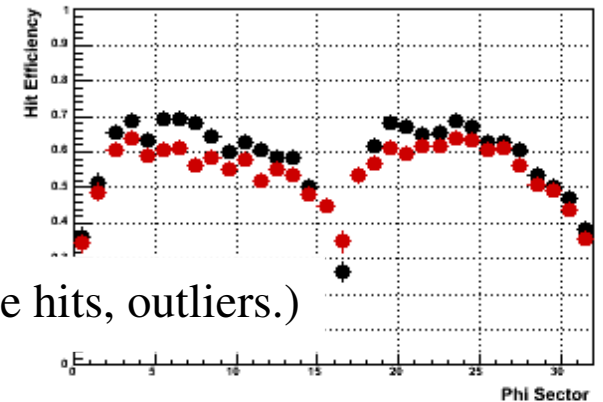
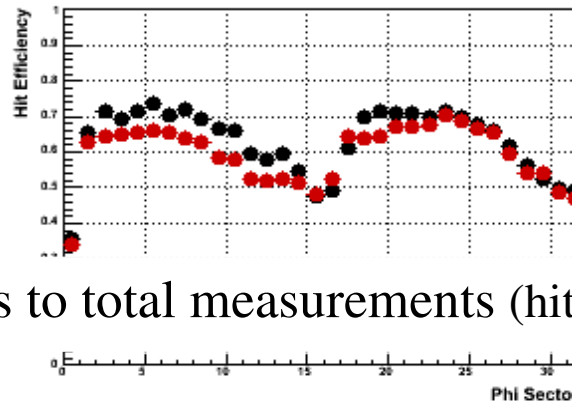
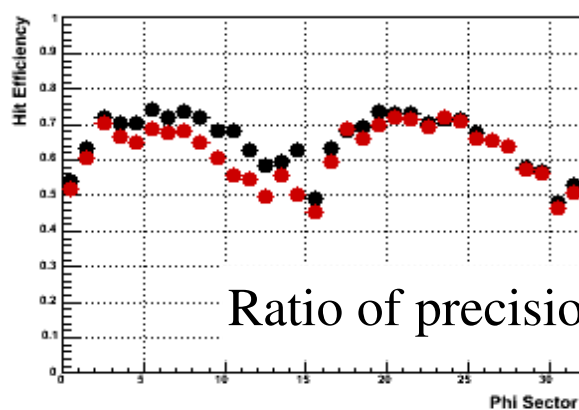
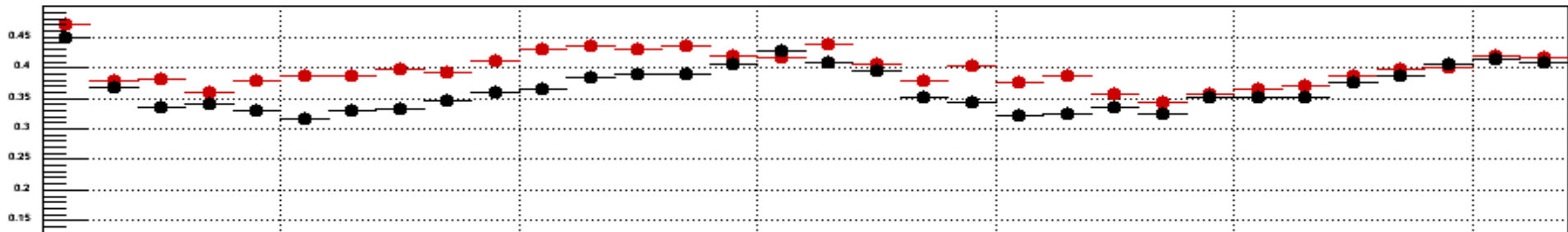

Ratio of precision hits to total measurements (hits, tube hits, outliers.)



TRT Endcap A

Endcap A was aligned in M6

Endcap A convergence again looks good, hits increase w/ iteration

Misalignments: translations $dx : O(1\text{mm})$, $dy : O(100 \text{ microns})$, $dz : O(1\text{mm})$
rotations $< \text{milli-radian}$

- Much larger differences than was seen in M6
Was expected.

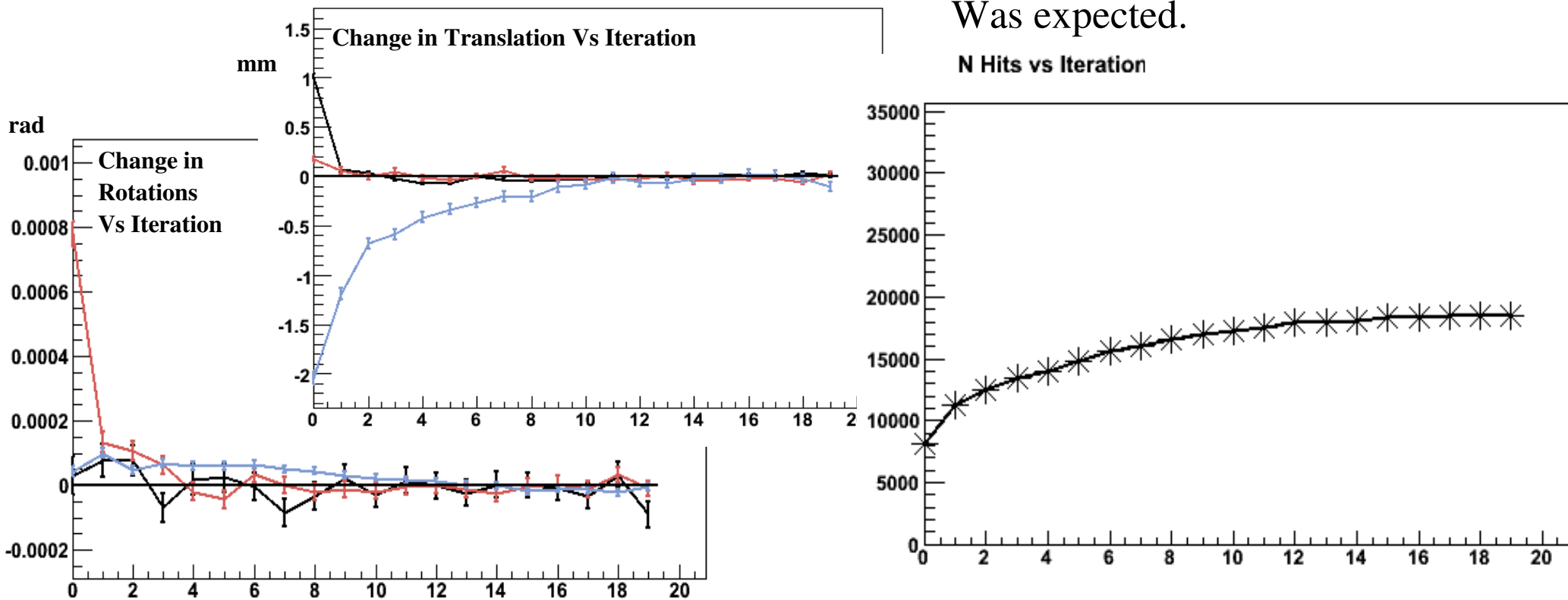



TRT Endcap A

Situation during M6: red- before alignment,
black – after alignment (No timing info.)

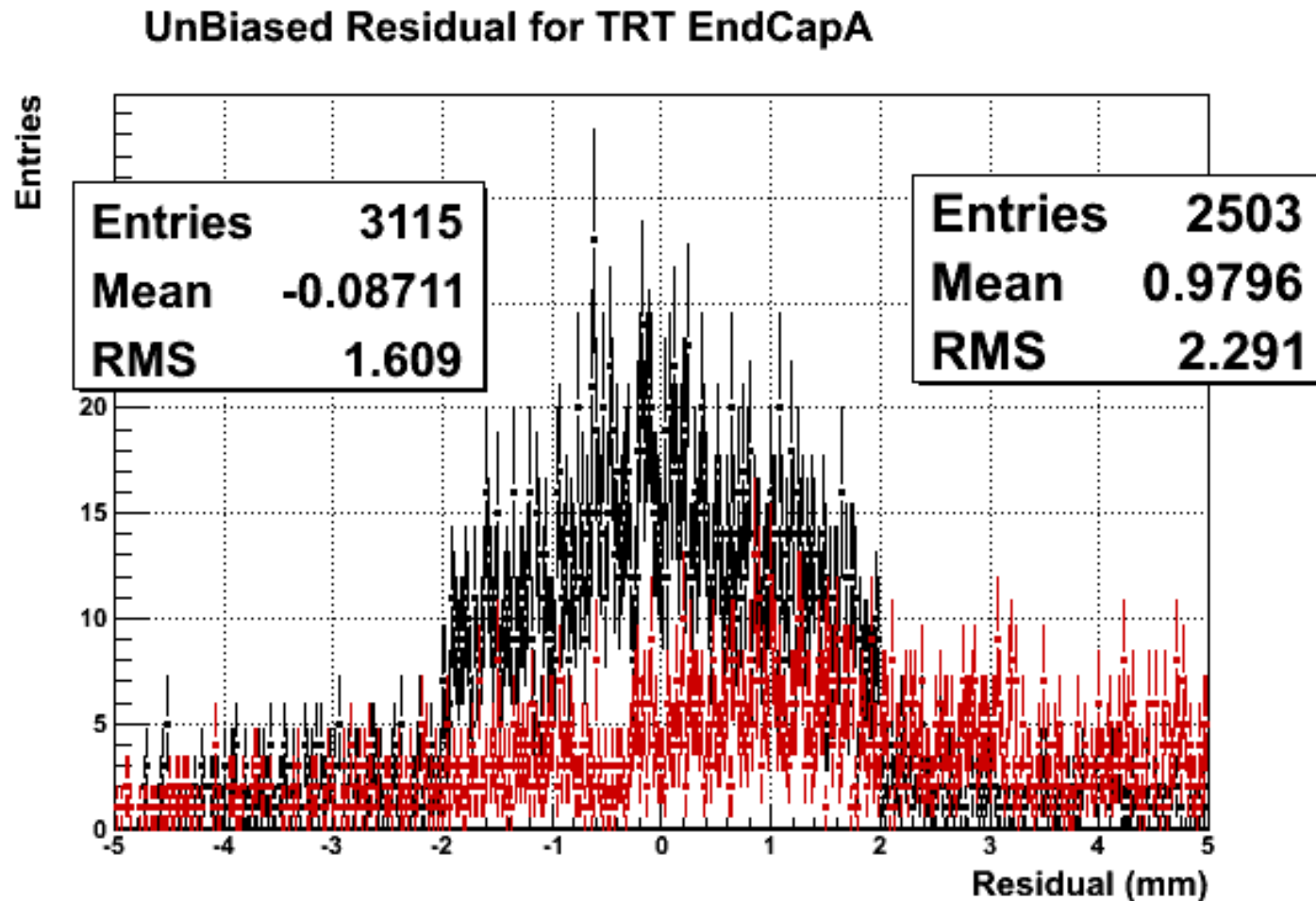



TRT Endcap A

Situation Now: red- before alignment, but using M6 results
black – after alignment (timing from CTB)

UnBiased Residual for TRT EndCapA

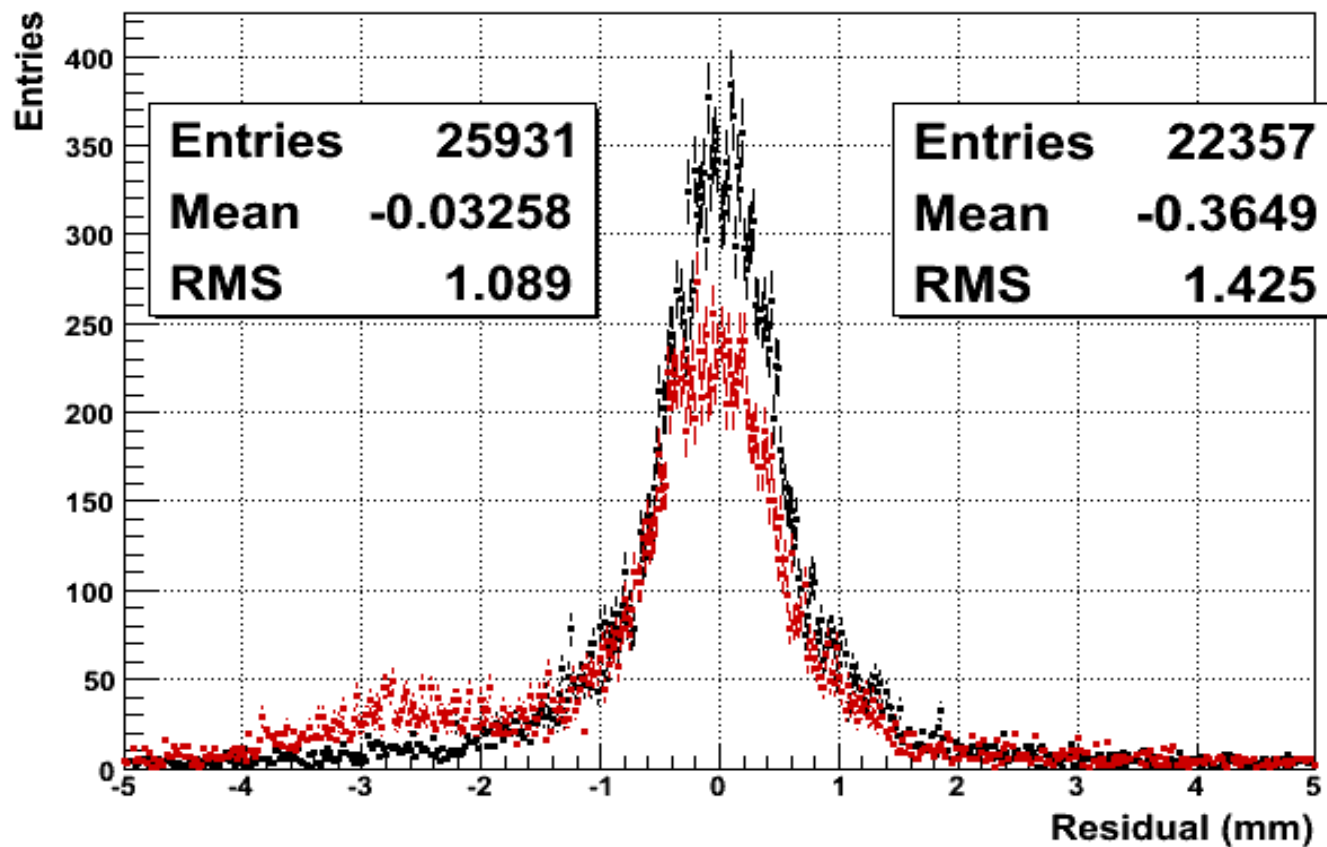



TRT Endcap A

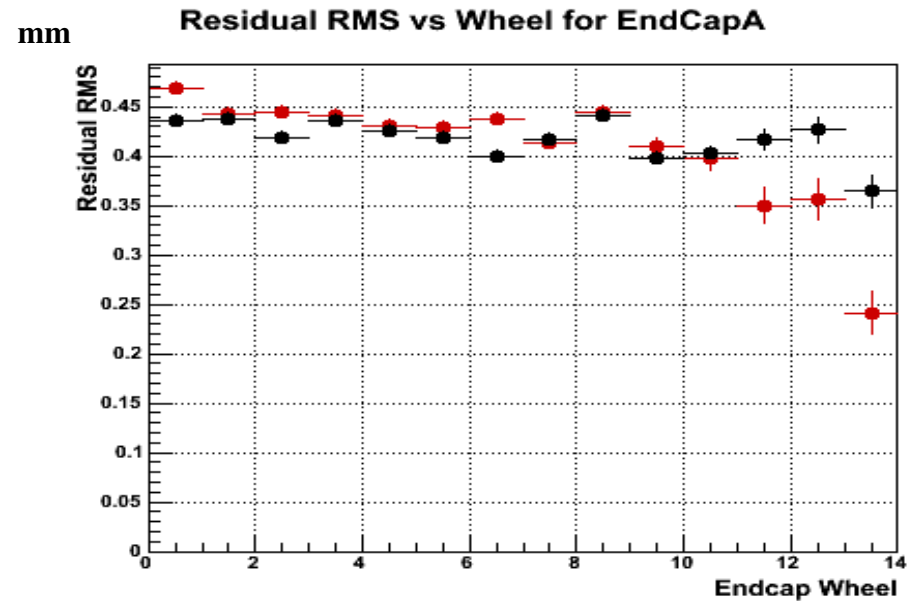
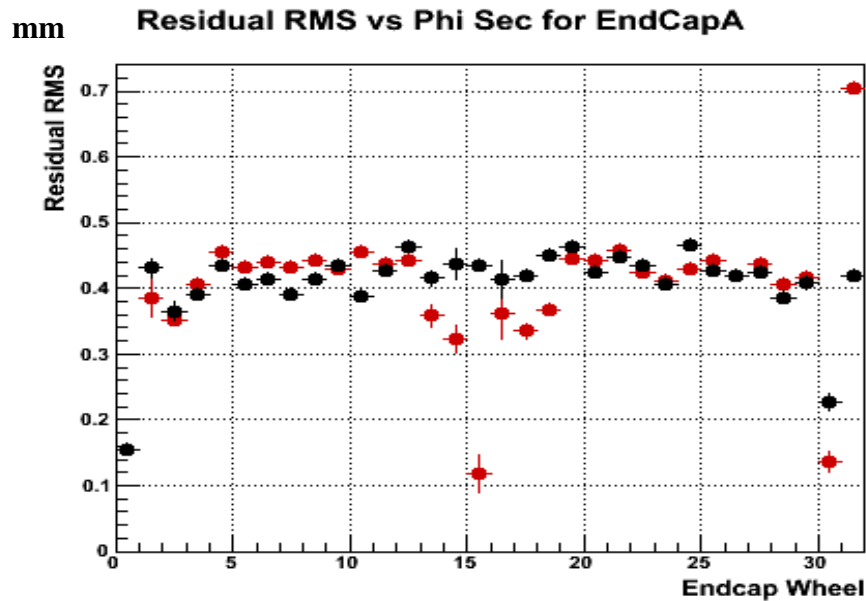
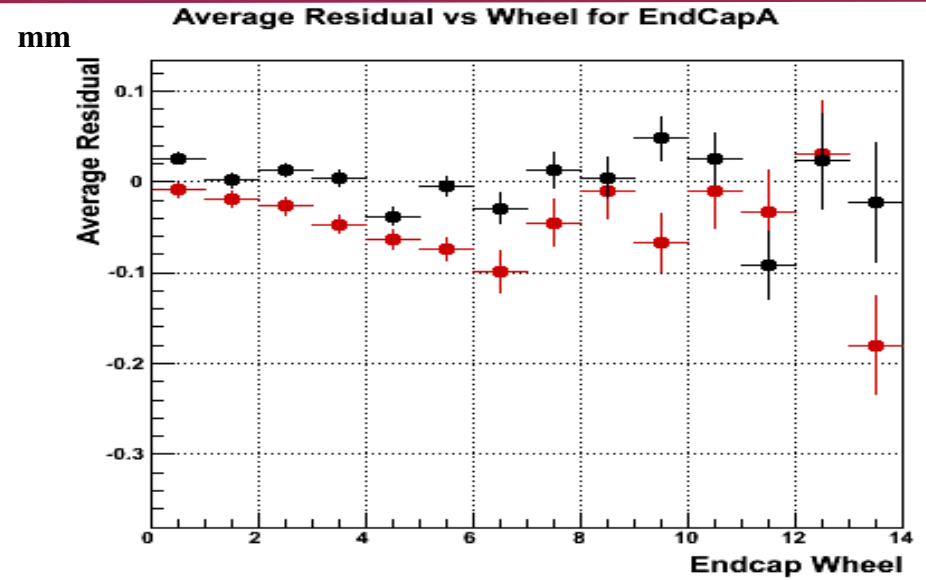
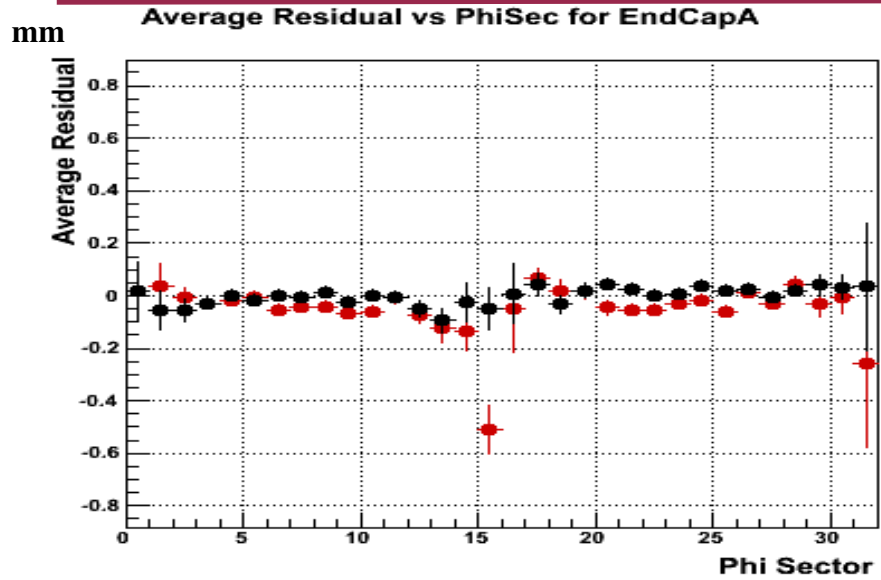



TRT Endcap A

Number of Hits vs Phi Sector

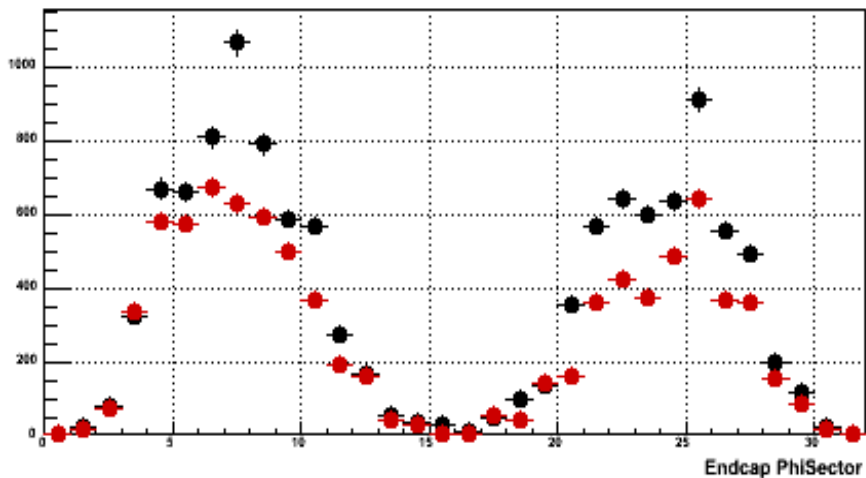

Number of Hits vs Wheel

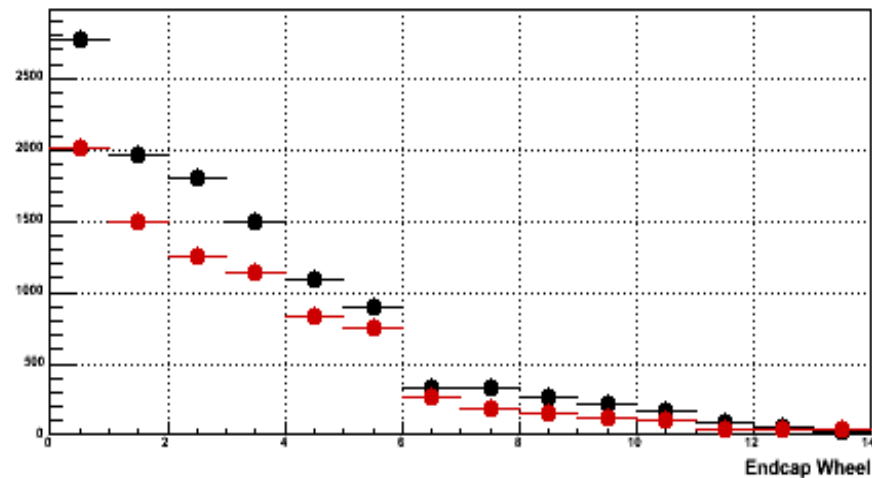

Ratio of hits to total measurements vs PhiSector for EndCapA

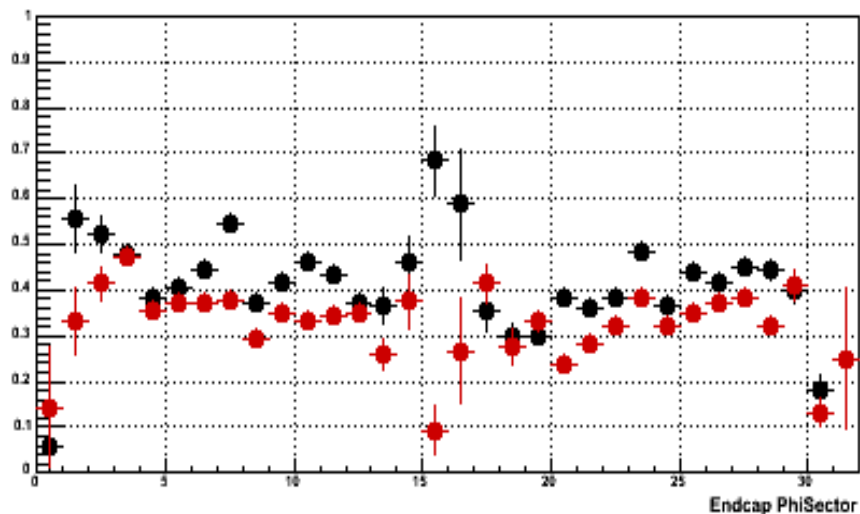

Ratio of hits to total measurements vs Wheel for EndCapA

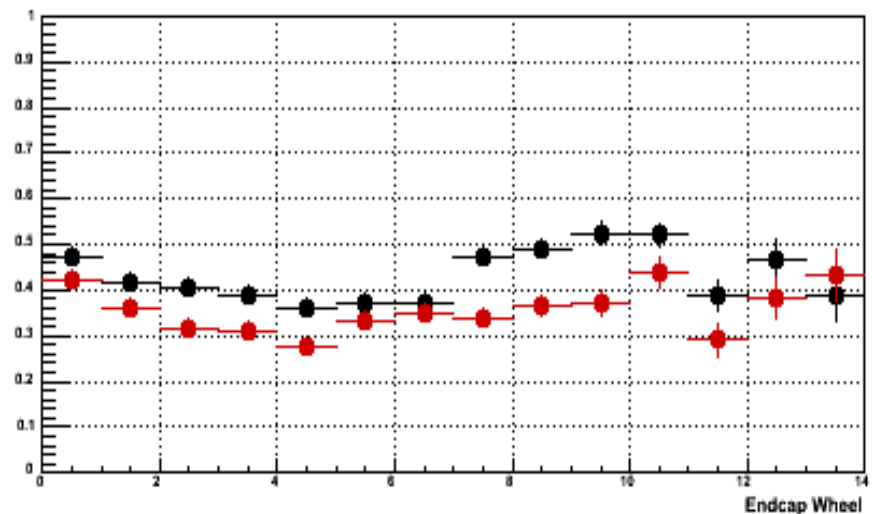



TRT Endcap C

Endcap C was NOT aligned in M6 (not read out)

Endcap C convergence incomplete, hits increase w/ iteration no plateau

Misalignments: translations dx & dy: O(1mm), dz : <100 microns

rotations rotx & y < milli-radian, rotz > 5 millirad!

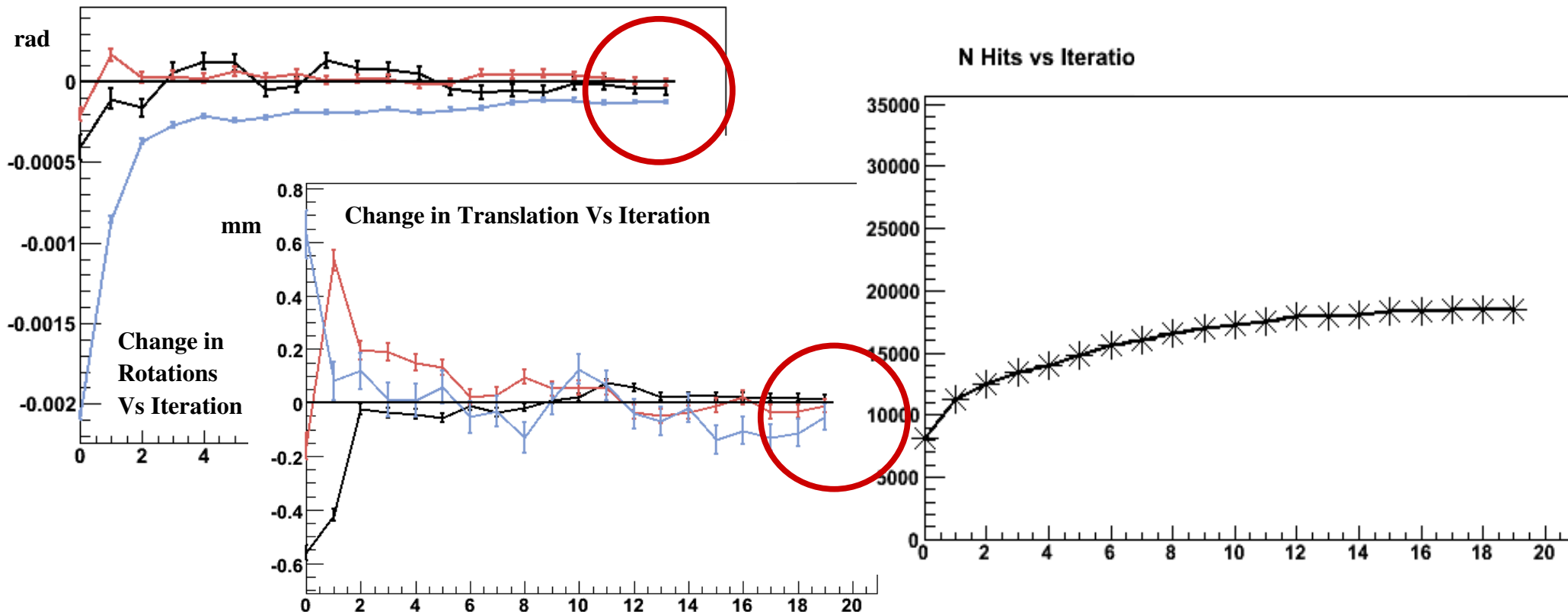



Endcap C

Resolution improvement in Endcap C (timing from CTB)

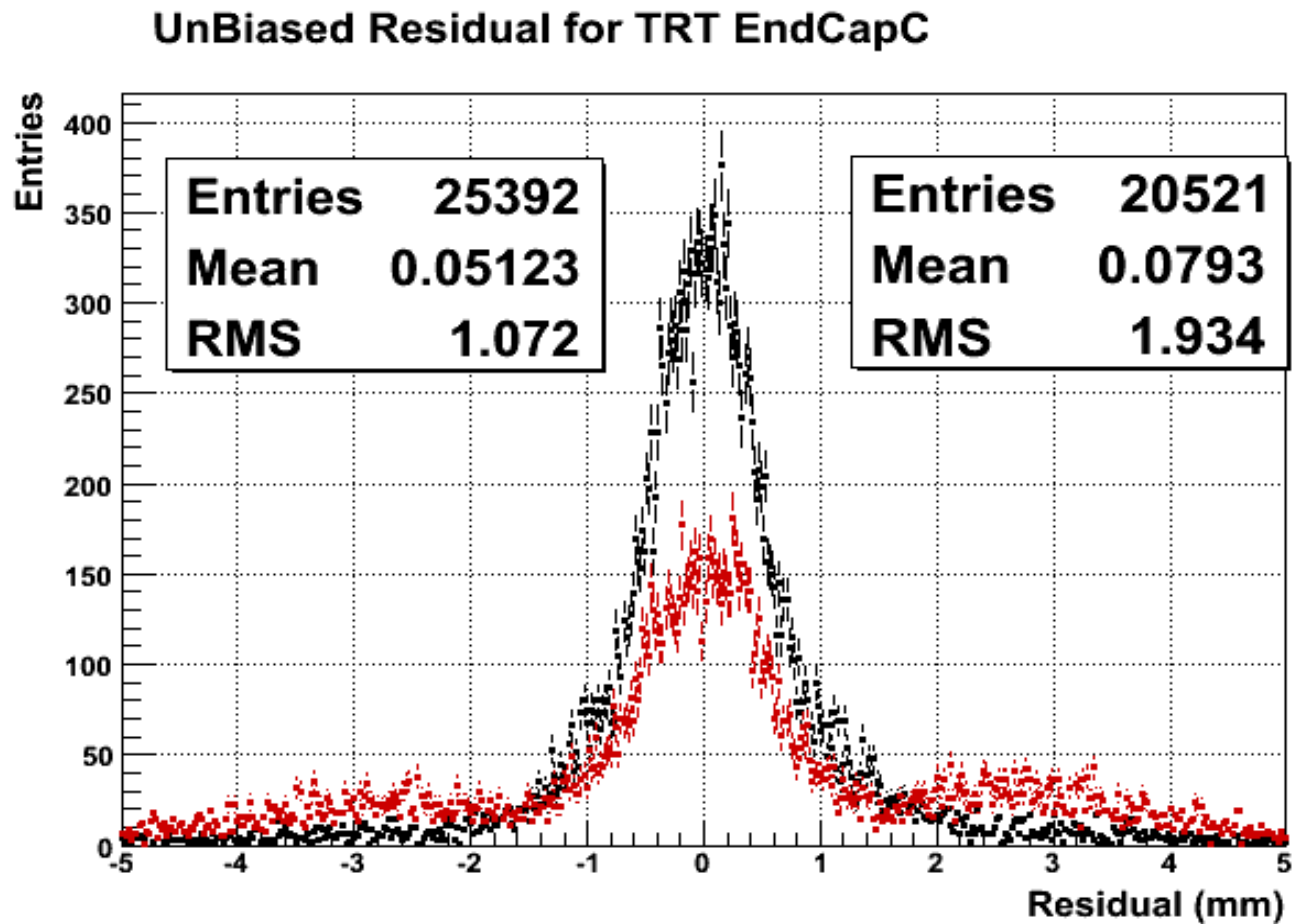



TRT Endcap C

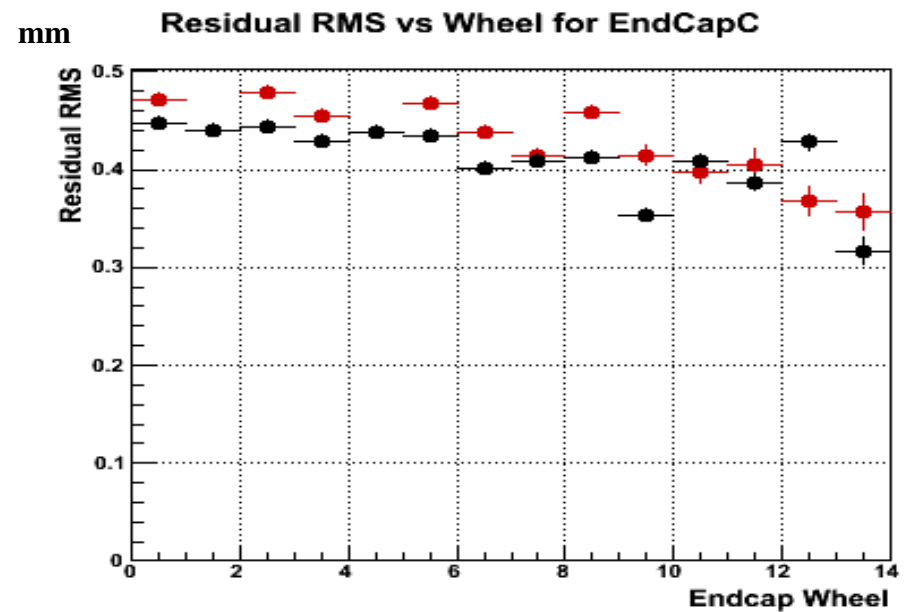
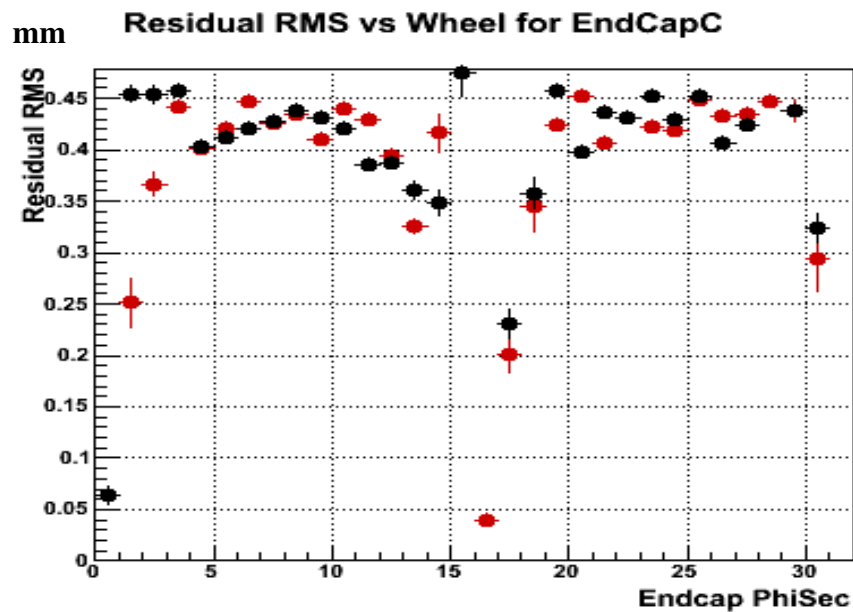
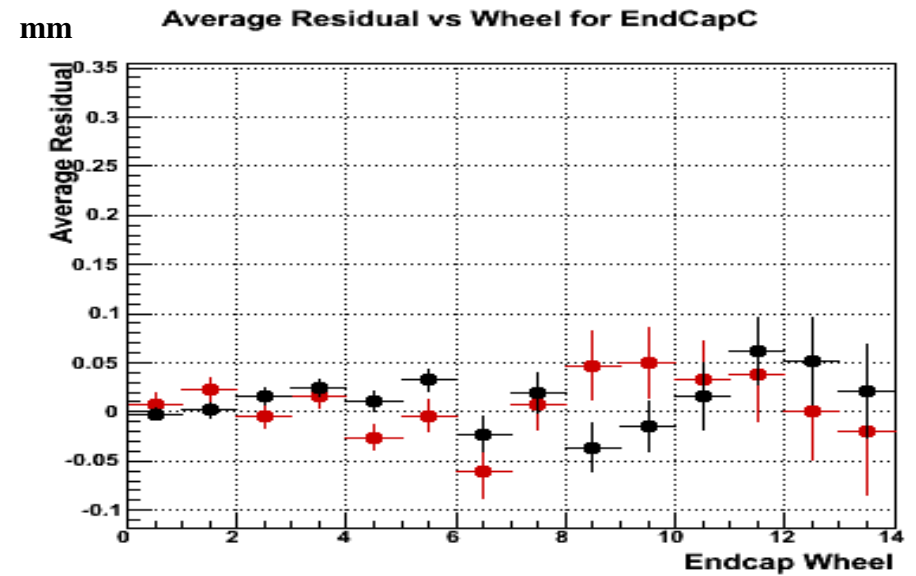
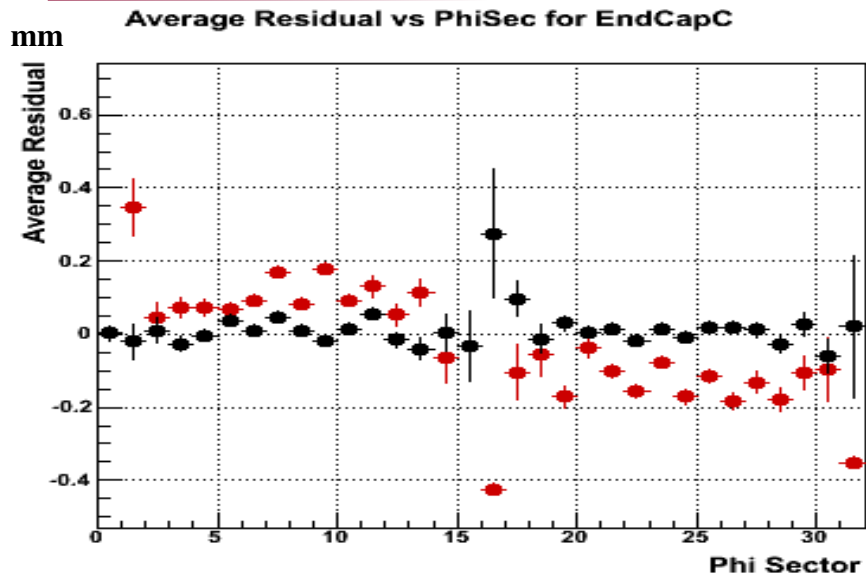



TRT Endcap C

Number of Hits vs Phi Sector

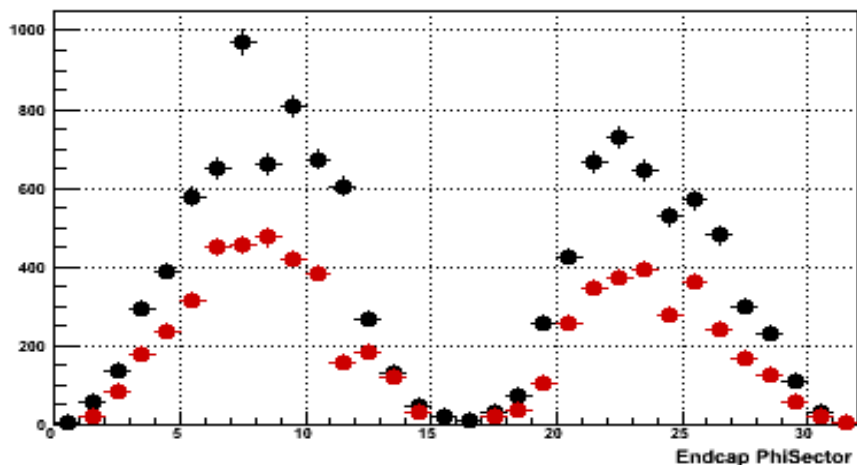

Number of Hits vs Wheel

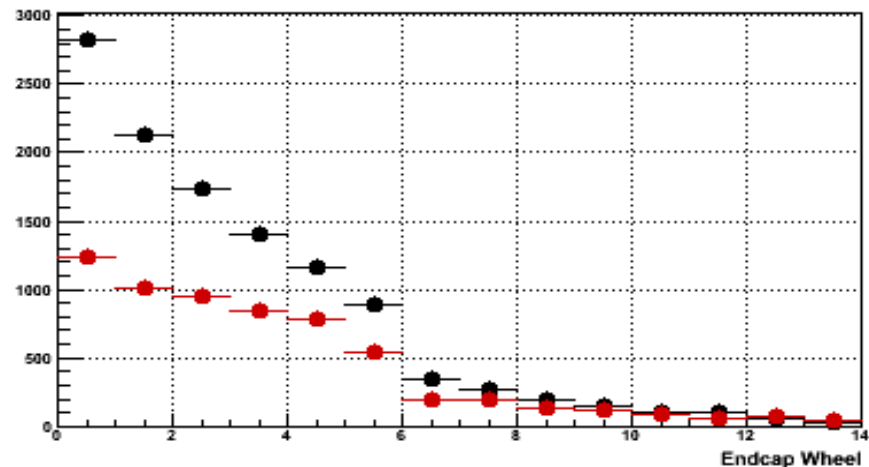

Ratio of hits(outliers) to total measurements vs PhiSector for EndCapC

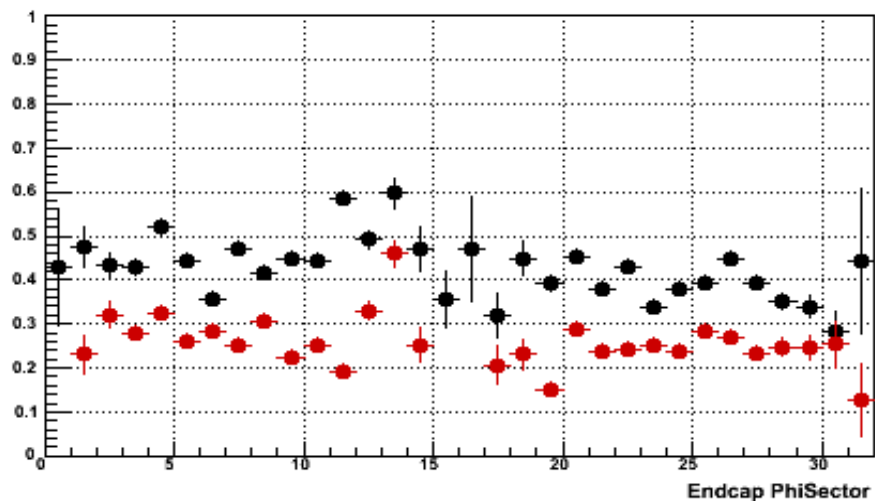

Ratio of hits(outliers) to total measurements vs Wheel for EndCapC

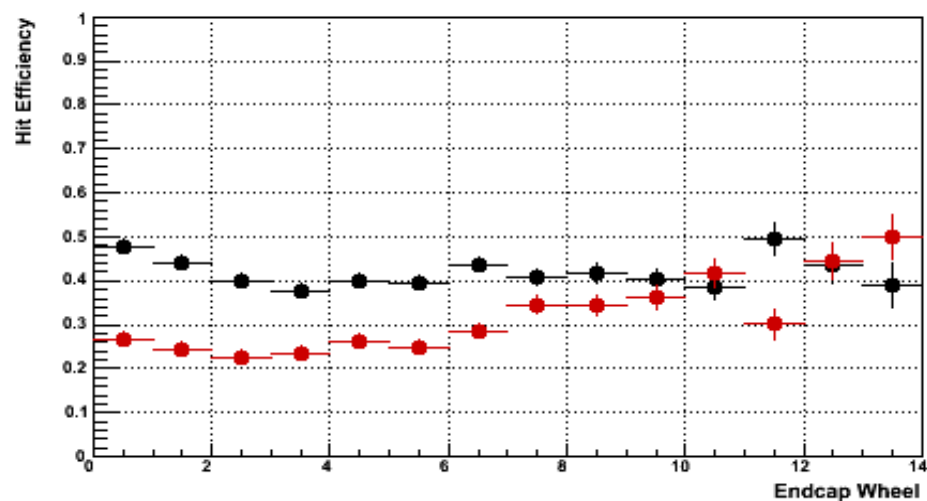



Next Steps/Conclusions

Improve Track Selection

- events with >1 track, SCT endcap hits, < 5 TRT endcap hits, event phase

Bootstrap L1 Alignment

- Split barrel and EC alignment into separate steps. Barrel alignment in DB ?

Tube Hits Endcaps

- Align Endcaps with tube hits
- if large misalignments found put in DB? (pattern rec/trigger)

Stable Running

- This week (?) stable running a priority, TRT calibration and much more statistics

L2 Alignment

- after a solid L1 alignment the obvious next step is L2 ... (L3?)